

# ACME



**Serie/Series ASP**

**Pompe peristaltiche a pressione  
Pressure hose pumps**

**Portata fino a 22.000 L/H – Capacity up to 22.000 L/H  
Prevalenza fino a 10 bar – Discharge pressure up to 10 bar**

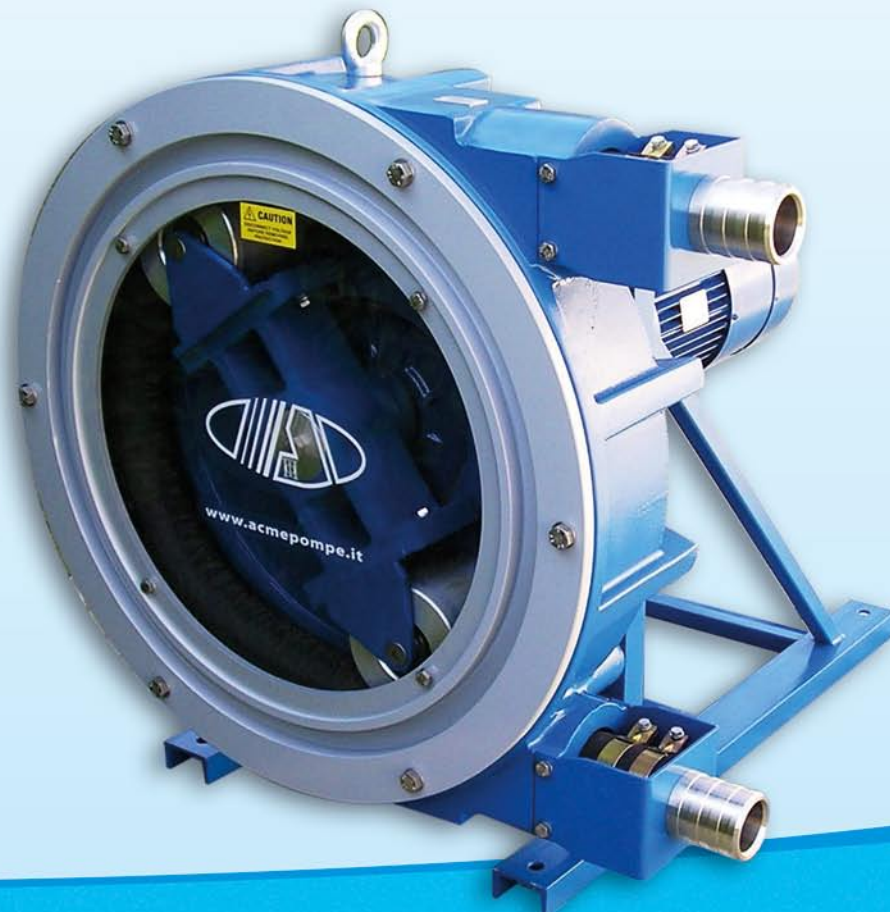

**Resistente ad acidi ed abrasivi – Autoadescante  
Abrasive and corrosive resistant – Self priming**



SERIE / SERIES

**ASP | FX**

PORTATA FISSA CON MOTORIDUTTORE / FIXED CAPACITY WITH GEARED MOTOR

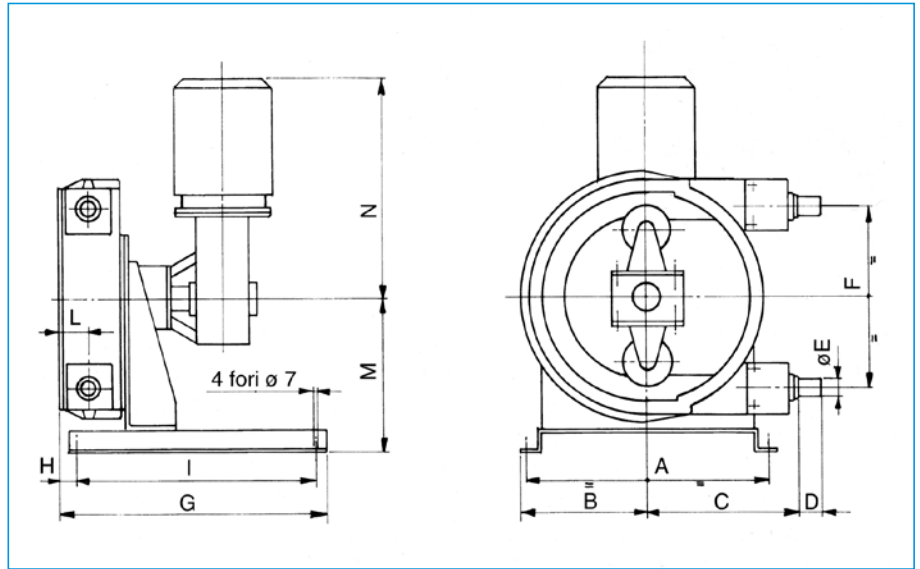

Dimensioni d'ingombro e pesi / Overall dimensions mm and weight

TIPO / TYPE	A	B	C	D	ø E	F	G	H	I	L	M	N	Kg.
<b>ASP 10 FX</b>	210	112	169	25	15	169	251	21	220	40	184	271	19
<b>ASP 15 FX</b>	210	112	169	30	20	169	251	21	220	40	184	271	20

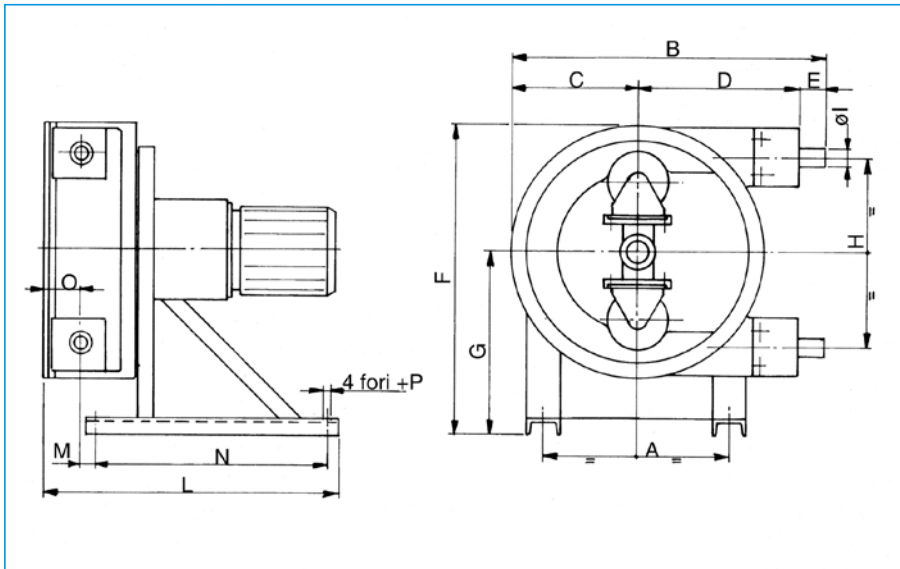

Dimensioni d'ingombro e pesi / Overall dimensions mm and weight

TIPO / TYPE	A	B	C	D	E	F	G	H	ø I	L	M	N	O	ø P	Kg.
<b>ASP 25 FX</b>	250	415	160	210	45	380	220	254	32	491	23	400	53	11	48
<b>ASP 32 FX</b>	330	573	217	290	66	517	300	316	40	655	47	520	68	11	84
<b>ASP 40 FX</b>	420	683	270	350	75	640	370	410	50	735	56	580	74	14	145
<b>ASP 50 FX</b>	420	790	330	380	80	770	440	518	65	833	70	650	88	14	185
<b>ASP 65 FX</b>	566	1041	440	510	91	1010	570	680	80	1107	36	930	106	17	478

**ASP | FX** | Caratteristiche tecniche / Technical characteristics

TIPO / TYPE	Q (l/h)	A	P	RPM	i	Kw	di	Qu	Nm
<b>ASP 10 FX</b>	47	8	100	23	60	0,18	10	0,034	35
	72	8	80	35	40	0,18			
	96	8	80	47	30	0,37			
	143	8	80	70	20	0,37			
<b>ASP 15 FX</b>	102	8	100	23	60	0,18	15	0,074	35
	155	8	80	35	40	0,18			
	209	8	80	47	30	0,37			
	310	8	80	70	20	0,37			
<b>ASP 25 FX</b>	672	8	80	35	40	0,55	25	0,32	40
	864	8	80	45	31,5	0,75			
	1075	8	70	56	25	0,75			
	1344	8	60	70	20	0,75			
<b>ASP 32 FX</b>	1596	8	100	38	37	1,1	32	0,70	75
	1974	8	70	47	30	1,1			
	2436	8	50	58	24	1,1			
	2940	8	40	70	20	1,1			
<b>ASP 40 FX</b>	2040	8	100	25	56	1,5	40	1,36	110
	2938	8	80	36	39	1,5			
	3672	8	60	45	31,5	1,5			
	5712	8	40	70	20	1,5			
<b>ASP 50 FX</b>	4185	8	100	25	56	2,2	50	2,79	200
	6026	8	60	36	39	2,2			
	7533	8	60	45	31,5	3			
	11718	8	40	70	20	3			
<b>ASP 65 FX</b>	8580	8	80	22	63	4	65	6,50	400
	13650	8	60	35	40	5,5			
	17550	8	60	45	31,5	7,5			
	21840	8	50	56	25	7,5			

Motore / Motor 3 PH - Volts 220/380 Hz 50 R.P.M. 1400 IP55

**A** = aspirazione in m / suction pressure in m  
**P** = prevalenza in m / discharge pressure in m  
**di** = diam. int. tubo / inn. diam. pump hose mm  
**Qu** = litri per giro / litres for revolution  
**Nm** = min. coppia di spunto / min. start. torque



SERIE / SERIES

ASP | VX

PORTATA VARIABILE CON MOTOVARIATORE / VARIABLE CAPACITY WITH MECHANICAL VARIATOR

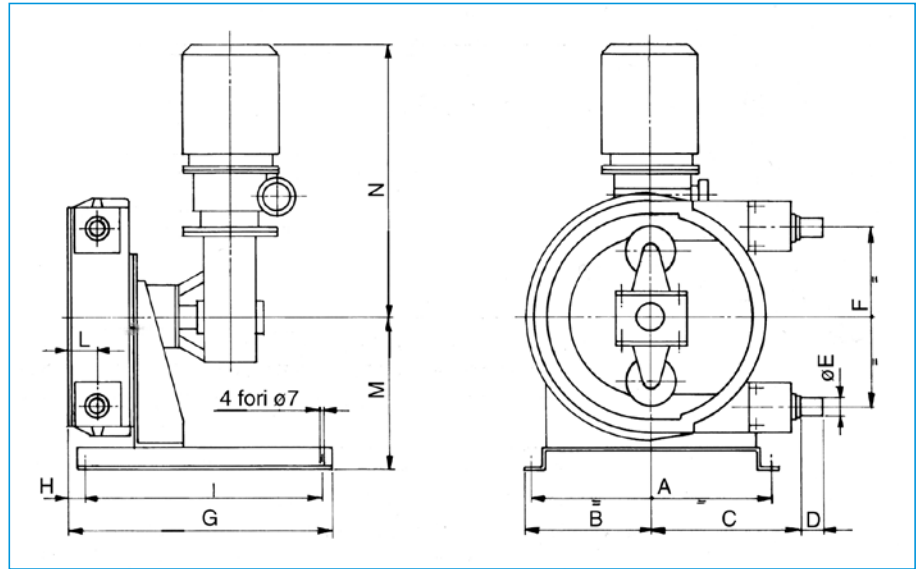

Dimensioni d'ingombro e pesi / Overall dimensions mm and weight

TIPO / TYPE	A	B	C	D	øE	F	G	H	I	L	M	N	Kg.
<b>ASP 10 VX</b>	210	112	169	25	15	169	251	21	220	40	184	394	23
<b>ASP 15 VX</b>	210	112	169	30	20	169	251	21	220	40	184	394	24

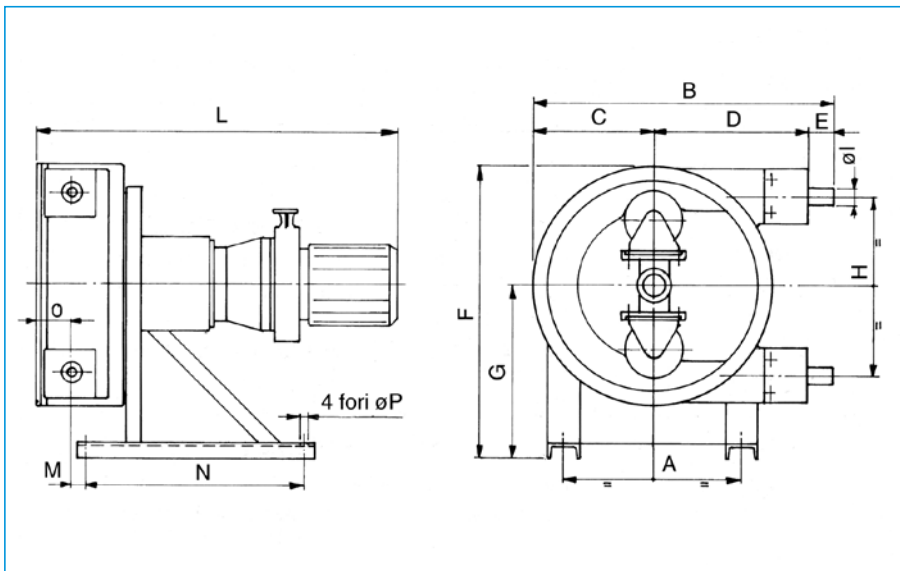

Dimensioni d'ingombro e pesi / Overall dimensions mm and weight

TIPO / TYPE	A	B	C	D	E	F	G	H	øI	L	M	N	O	øP	Kg.
<b>ASP 25 VX</b>	250	415	160	210	45	380	220	254	32	491	23	400	53	11	55
<b>ASP 32 VX</b>	330	573	217	290	66	517	300	316	40	655	47	520	68	11	95
<b>ASP 40 VX</b>	420	683	270	350	75	640	370	410	50	735	56	580	74	14	164
<b>ASP 50 VX</b>	420	790	330	380	80	770	440	518	65	833	70	650	88	14	204
<b>ASP 65 VX</b>	566	1041	440	510	91	1010	570	680	80	1107	36	930	106	17	530

**ASP | VX** | Caratteristiche tecniche / *Technical characteristics*

TIPO / TYPE	Q (l/h)	A	P	RPM	i	Kw	di	Qu	Nm
<b>ASP 10 VX</b>	6,5÷30,6	8	100	3,2÷15	60	0,22	10	0,034	35
	9,6÷46	8	70	4,7÷22,5	40	0,22			
	15,5÷77,5	8	60	7,6÷38	25	0,37			
	26÷129	8	50	12,7÷63,3	15	0,37			
<b>ASP 15 VX</b>	14,2÷66,6	8	100	3,2÷15	60	0,22	15	0,074	35
	21÷100	8	70	4,7÷22,5	40	0,22			
	34÷168,7	8	60	7,6÷38	25	0,37			
	56,4÷281	8	50	12,7÷63,3	15	0,37			
<b>ASP 25 VX</b>	90÷480	8	60	4,7÷25	40	0,37	25	0,32	40
	146÷768	8	60	7,6÷40	25	0,75			
	230÷1190	8	50	12÷62	16	0,75			
	288÷1536	8	40	15÷80	12,5	0,75			
<b>ASP 32 VX</b>	210÷1134	8	60	5÷27	37	1,1	32	0,70	75
	319÷1680	8	60	7,6÷40	25	1,1			
	504÷2604	8	50	12÷62	16	1,1			
	630÷3360	8	40	15÷80	12,5	1,1			
<b>ASP 40 VX</b>	342÷1811	8	60	4,2÷22,2	45	1,5	40	1,36	110
	489÷2611	8	60	6÷32	31,5	1,5			
	775÷4080	8	50	9,5÷50	20	2,2			
	979÷5059	8	40	12÷62	16	2,2			
<b>ASP 50 VX</b>	703÷3716	8	60	4,2÷22,2	45	2,2	50	2,79	200
	1004÷5356	8	60	6÷32	31,5	2,2			
	1590÷8370	8	50	9,5÷50	20	3			
	2008÷10378	8	40	12÷62	16	3			
<b>ASP 65 VX</b>	1638÷8658	8	60	4,2÷22,2	45	4	65	6,50	400
	2340÷12480	8	60	6÷32	31,5	5,5			
	2964÷15600	8	50	7,6÷40	25	7,5			
	3705÷19500	8	40	9,5÷50	20	7,5			

Motore / Motor 3 PH - Volts 220/380 Hz 50 R.P.M. 1400 IP55

**A** = aspirazione in m / *suction pressure in m*  
**P** = prevalenza in m / *discharge pressure in m*  
**di** = diam. int. tubo / *inn. diam. pump hose mm*  
**Qu** = litri per giro / *litres for revolution*  
**Nm** = min. coppia di spunto / *min. start. torque*



SERIE / SERIES

**ASP | IX**

PORTATA VARIABILE CON VARIATORE ELETTRONICO DI FREQUENZA (INVERTER) /  
VARIABLE CAPACITY WITH ELECTRONIC FREQUENCY VARIATOR (INVERTER)

Per informazioni tecniche  
contattare il nostro  
ufficio tecnico

*For technical informations  
please contact our  
technical department*



SERIE / SERIES

**ASP 2. | \_**

POMPE A DOPPIA TESTA / DOUBLE HEAD PUMPS



Per informazioni tecniche  
contattare il nostro  
ufficio tecnico

*For technical informations  
please contact our  
technical department*

SERIE / SERIES

**ASP | TX**

TESTE POMPANTI / PUMP HEADS

Per informazioni tecniche  
contattare il nostro  
ufficio tecnico

*For technical informations  
please contact our  
technical department*





ASP 10

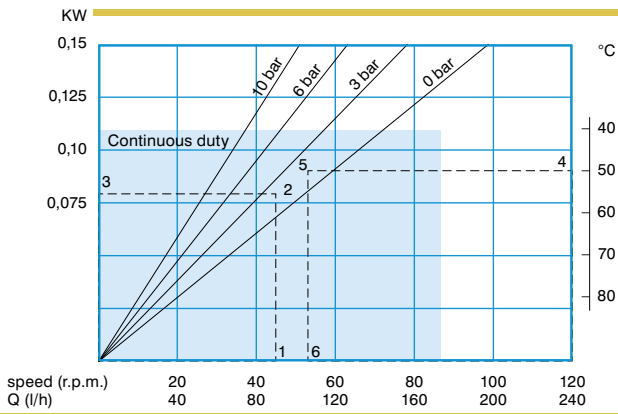

ASP 40

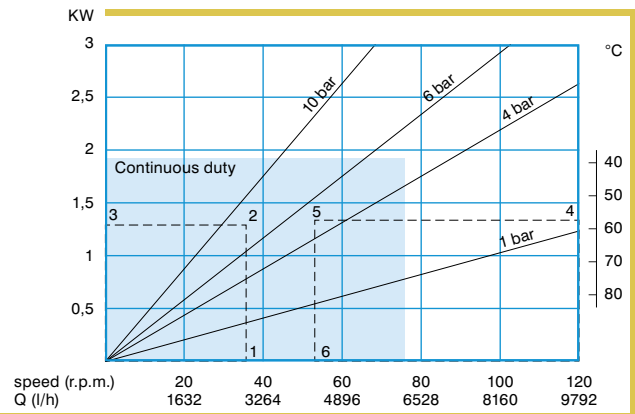

ASP 15

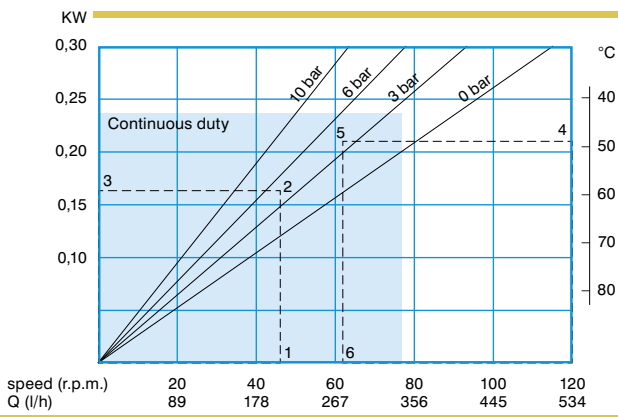

ASP 50

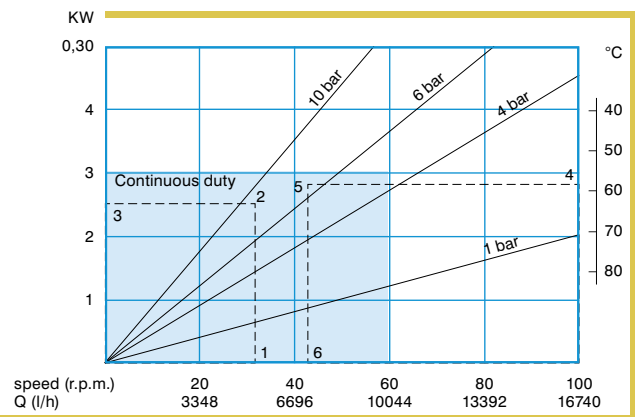

ASP 25

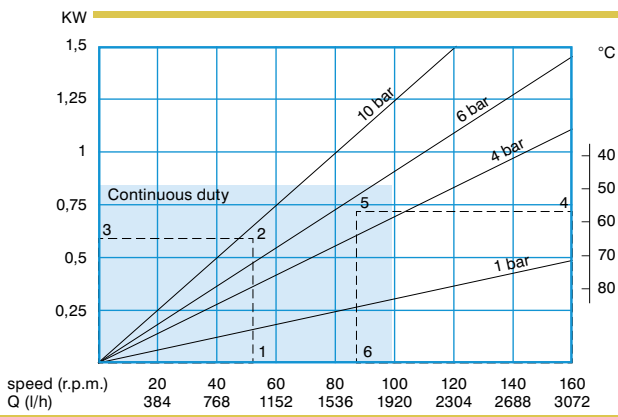

ASP 65

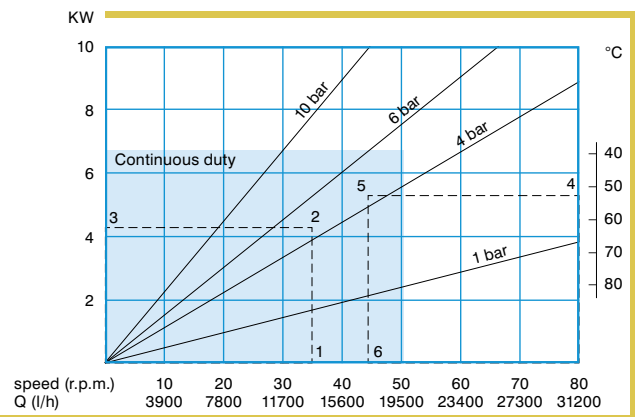

ASP 32

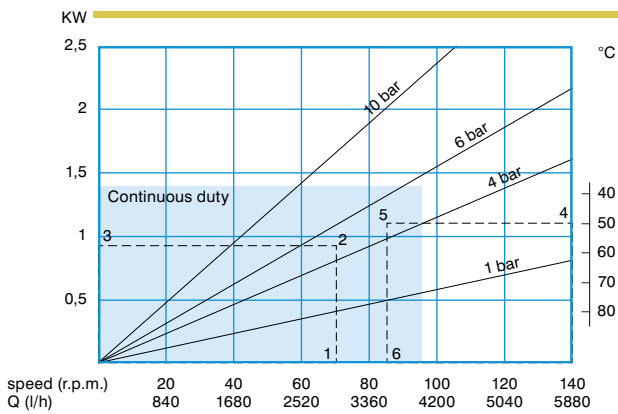

COME SI USA IL DIAGRAMMA

1. La velocità della pompa determina la portata richiesta.
2. Prevalenza calcolata.
3. Potenza effettiva richiesta.
4. Temperatura del fluido.
5. Prevalenza calcolata.
6. Massima velocità consigliata.

Tutti i valori descritti sono riferibili ad acqua e prodotto con eguali caratteristiche.

HOW TO USE THE CURVES

1. Flow required indicates pump speed.
2. Calculated discharge pressure.
3. Net motor power required.
4. Fluid temperature.
5. Calculated discharge pressure.
6. Maximum recommended pump speed.

The operating data here described refer to water or similar peculiarity fluid.

### Applicazioni

Impianti di trattamento acque, acque di scarico, industria chimica e petrolchimica, cartiere, industria tessile, industria ceramica, edilizia, industria mineraria, vernici e inchiostri, olii emulsionabili, industria alimentare e casearia, pastifici, settore enologico e di imbottigliamento, industria farmaceutica e cosmetica, concerie.

### Typical applications

Water purification plants, chemical and petrochemical industries, paper mills, textil industries, ceramics, building, mining industries inks and paints, emulsible oils, food industries and dairies, alimentary paste industries, wine and bottling plants, pharmaceutical and cosmetic industries, tanneries.

### Particolarmente adatta per:

- prodotti abrasivi
- prodotti acidi
- prodotti sensibili
- prodotti viscosi
- prodotti densi
- dosaggi
- vuoto
- impiego in ambienti esplosivi

### Highly suitable for:

- abrasive products
- corrosive products
- shear sensitive products
- viscous products
- high density products
- metering purposes
- vacuum situations
- use in explosive environments

### Materiali

1	Corpo pompa Asp 10-15	lega di alluminio ghisa
2	Rotore	lega di alluminio
3	Rulli Asp 10-15	lega di alluminio nylatron
4	Basamento	ferro
5	Attacchi standard	AISI 304
	Attacchi speciali DIN, TRI-CLAMPS, ANSI, ecc.	AISI 316 PVC PTFE Polipropilene

### Materials

1	Pump casing Asp 10-15	aluminium alloy cast iron
2	Rotor	aluminium alloy
3	Rollers Asp 10-15	aluminium alloy nylatron
4	Base	iron
5	Standard couplings	304 stainless steel
	Special couplings DIN, TRI-CLAMPS, ANSI, ecc.	316 stainless steel PVC PTFE Polypropylene

### Tubi

I tubi delle pompe ASP hanno struttura multistrato e sono disponibili in un'ampia gamma di mescole, scelte in funzione del fluido pompato.

### Hoses

Multilayer hoses with textile insert reinforcement, available in several compounds, to chose according to the piped fluid and work conditions.

