



MIDGETBOX

1/4" connections



PERFORMANCE

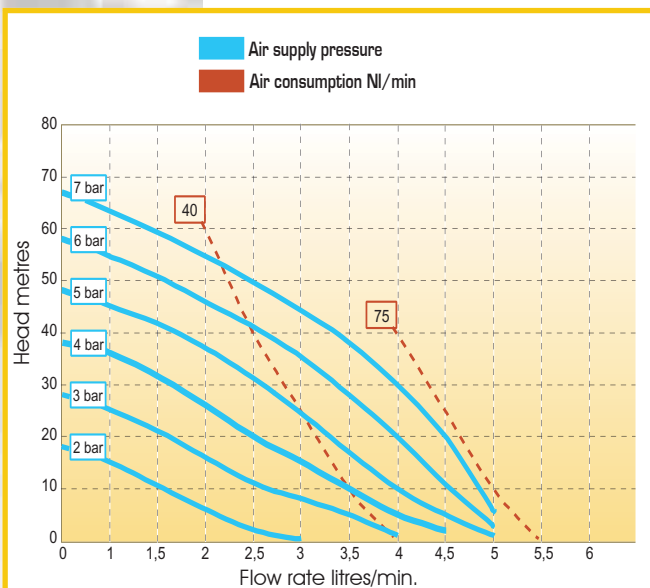

Intake/delivery connections	G 1/4
Air connection	G 1/8
Max. dry suction capacity*	3 m
Max. flow rate*	5 l/min
Max. head*	70 m
Max. air supply pressure	7 bar
Max. diameter of passing solids (spherical particles)	0 mm
Net weight	PP 0,5 Kg (zone 2) 60°C Max temp.
Construction material	PP

* The curves and performance values refer to pumps with submerged suction and a free delivery outlet with water at 20°C, and vary according to the construction material.

TECHNICAL DATA..

DIMENSIONS

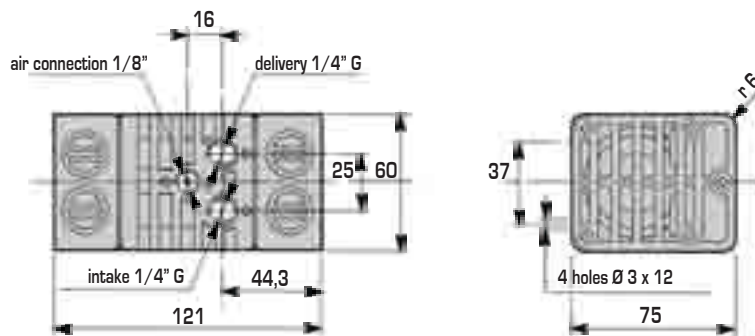

The dimensions shown are in millimetres, are indicative and are not binding; ask for the specific drawing.